

Mounting Artwork

Getting started

Now that your frame kit has arrived, let's get your art into its new home. Assembly instructions differ depending on the frame's moulding (wood or metal) and hardware type.

Turn to page 4 if you have a wood frame, and page 12 if you have a metal frame. Then, follow the instructions matching the hanging hardware on the back of your frame.

Mounting art in wood frames 4

Mounting art in metal frames 12

Wood frames

Prepare your workspace

- 1 Choose a clean, dust-free surface with ample room to work.
- 2 Unpack your frame kit and lay the frame face down.
Make sure to hold onto your hanging guide.

Tools needed by hardware type

Cleat

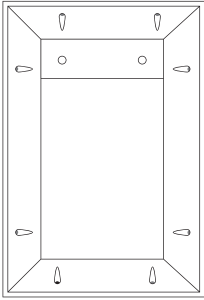

Corners

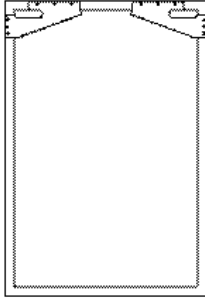

Sawtooth

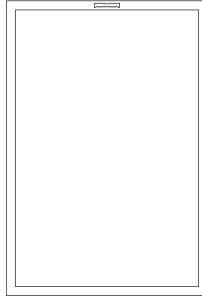

Wire

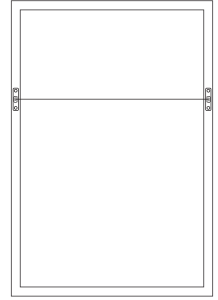

Phillips head screwdriver



Flat head screwdriver



Flat head screwdriver



Flat head screwdriver

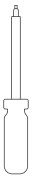

Square tip screwdriver

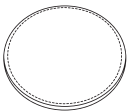

Weighted object

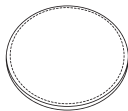

Weighted object

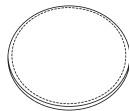

Weighted object



Weighted object

Take it apart

Cleat

1 Remove screws

Remove the cleat from the back of the frame and set aside. Then, using a square tip screwdriver, LOOSEN each screw from the strainer. Lift the strainer out of the frame and set aside. Carefully remove the backing board and mat board (if ordered), leaving the acrylic inside the frame.

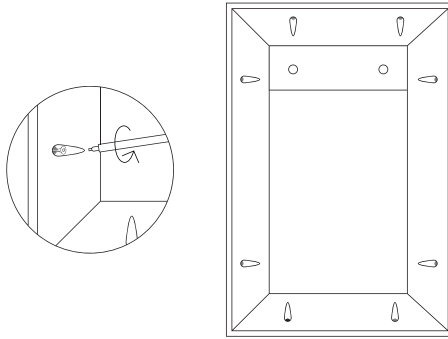

Corners/Sawtooth

1 Bend flex points up

Using a flat head screwdriver, bend all the flex points upwards and carefully remove the backing board and mat board (if ordered), leaving the acrylic inside the frame.

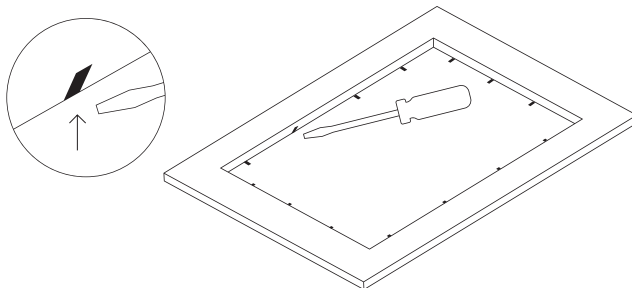

Wire

1 Remove hanging hardware on one side

Using a Phillips head screwdriver, unscrew the hanging hardware on the right-hand side of the frame, keeping one side attached to the frame.

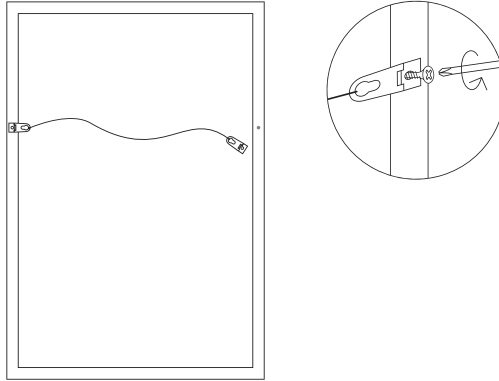

2 Bend flex points up

Using a flat head screwdriver, bend all the flex points upwards and carefully remove the backing board and mat board (if ordered), leaving the acrylic inside the frame.

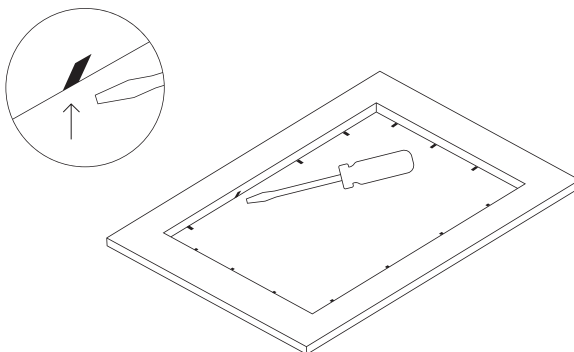

Mount artwork with a mat

If you did not order a mat, skip ahead to page 10.

1 Flatten artwork

Center the mat board on top of the artwork, so the correct portion of the artwork shows through the mat opening.

Keeping the mat board and artwork together, gently flip over onto a clean surface. The artwork should now be face down on the back of the mat board.

Use a clean weighted object, such as a hardcover book or paperweight, to hold down the corners of the artwork.

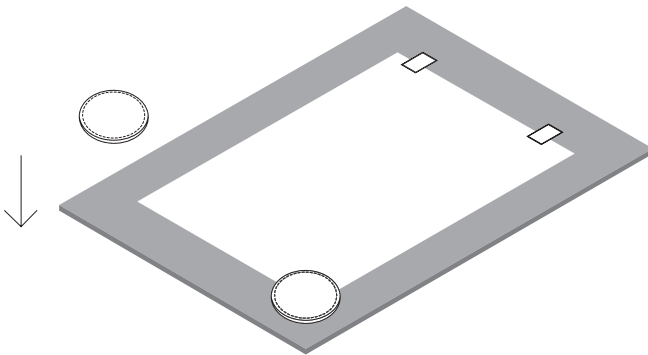

2 Apply hinge tape

To keep the artwork in place, gently apply a vertical strip of tape to the backside of the artwork, attaching it to the mat board. Never tape directly on the face of the artwork.

Then, apply a horizontal strip of tape, creating a T-shape with the two strips of tape (as seen below). Repeat three more times and remove the weights as you go.

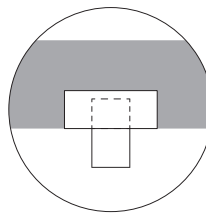
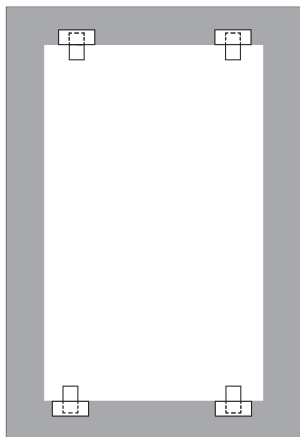
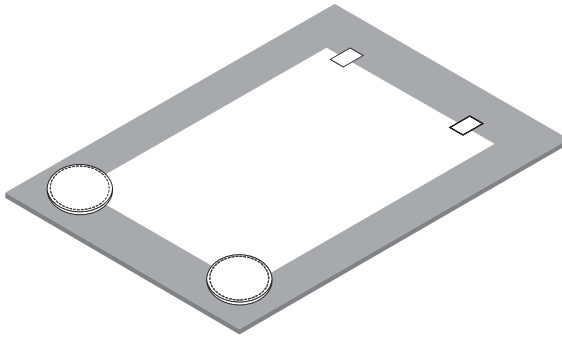

Put it back together

1 Sandwich the contents

Stack the contents of the frame in the following order: mat (if ordered), artwork, backing board. Re-insert the stack into the frame on top of the acrylic.

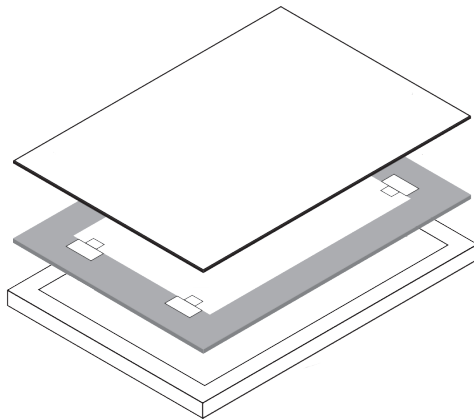

Cleat

2 Secure the strainer

Use a square-tip screwdriver and the provided screws to secure the strainer back inside the frame. The screws will lightly poke the inside of the frame to keep it secure.

Corners/Sawtooth

2 Bend flex points down

Using a flat head screwdriver, bend down the flex points to secure the artwork inside the frame.

Wire

2 Bend flex points down

Using a flat head screwdriver, bend down the flex points to secure the artwork inside the frame.

3 Re-attach hardware

Using a Phillips head screwdriver, re-attach the hanging hardware to the right-hand side of the frame (previously removed on page 7).

Metal frames

Prepare your workspace

- 1 Choose a clean, dust-free surface with ample room to work.
- 2 Unpack your frame kit and lay the frame face down.
Make sure to hold onto your hanging guide.

Tools needed by hardware

Corners

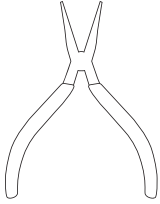
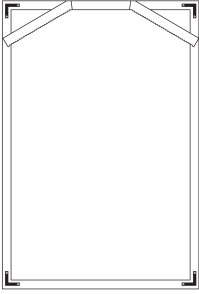

Needle nose pliers



Phillips head screwdriver



Weighted object

Sawtooth

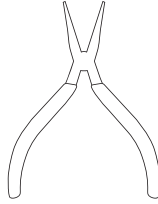
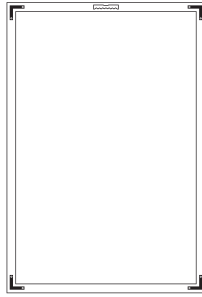

Needle nose pliers



Phillips head screwdriver

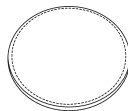

Weighted object

Wire

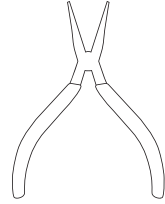
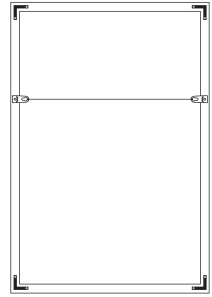

Needle nose pliers



Phillips head screwdriver

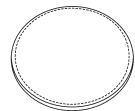

Weighted object

Take it apart

1 Remove spring clips

Remove spring clips one at a time. Place a finger on the edge of the spring clip. Push down towards the backing board and gently slide the clip out from under the frame at an angle. Repeat until all clips are removed. Set spring clips aside. If hard to remove, use needle nose pliers.

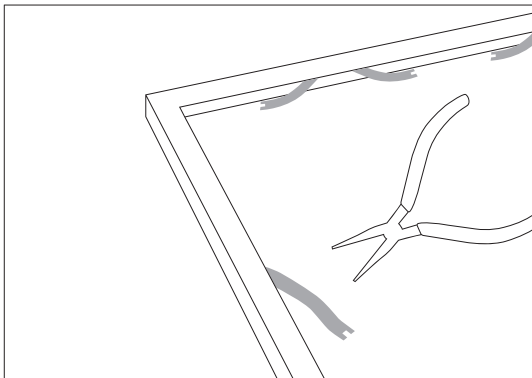

2 Remove the bottom

Based on the orientation of your artwork, determine which side of the frame will be the bottom. Then, using a Phillips head screwdriver, LOOSEN the screws of the bottom two corner brackets. DO NOT attempt to remove each screw, only LOOSEN.

Slide out the bottom portion of the frame. Set aside.

Then, carefully slide out the acrylic, backing board, and mat (if ordered) from inside the frame.

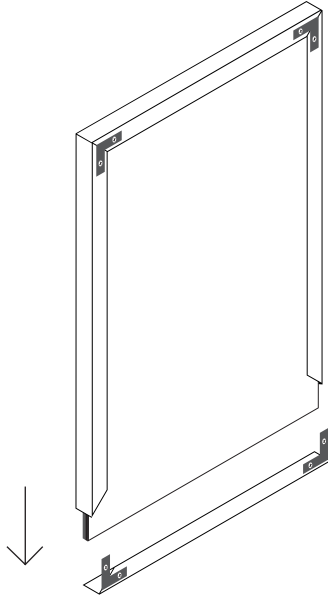

Mount artwork with a mat

If you did not order a mat, skip ahead to page 18.

1 Flatten artwork

Center the mat board on top of the artwork, so the correct portion of the artwork shows through the mat opening.

Keeping the mat board and artwork together, gently flip over onto a clean surface. The artwork should now be face down on the back of the mat board.

Use a clean weighted object, such as a hardcover book or paperweight, to hold down the corners of the artwork.

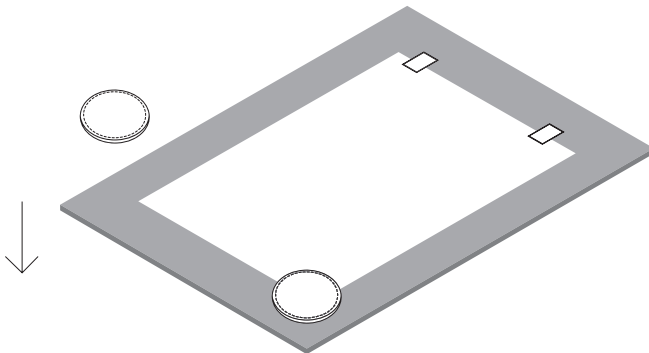

2 Apply hinge tape

To keep the artwork in place, gently apply a vertical strip of tape to the backside of the artwork, attaching it to the mat board. Never tape directly on the face of the artwork.

Then, apply a horizontal strip of tape, creating a T-shape with the two strips of tape (as seen below). Repeat three more times and remove the weights as you go.

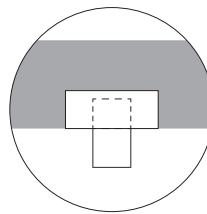
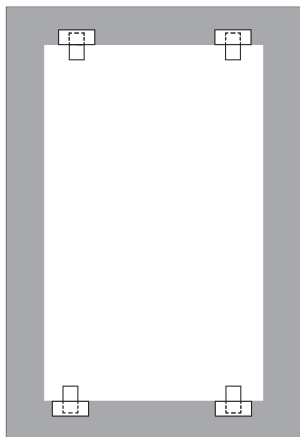
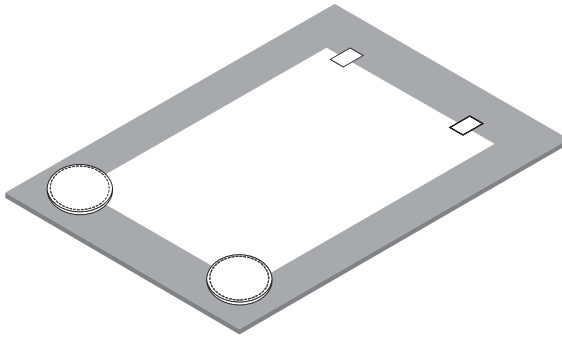

Put it back together

1 Sandwich the contents

Stack the contents of the frame in the following order: acrylic, mat (if ordered), artwork, backing board. Carefully slide the stack back into the 3-side frame.

2 Re-attach the bottom

Slide the bottom portion of the frame with corner brackets loosely attached back into place. Re-adjust corners as necessary so that all corners align. Tighten the screws to keep in place.

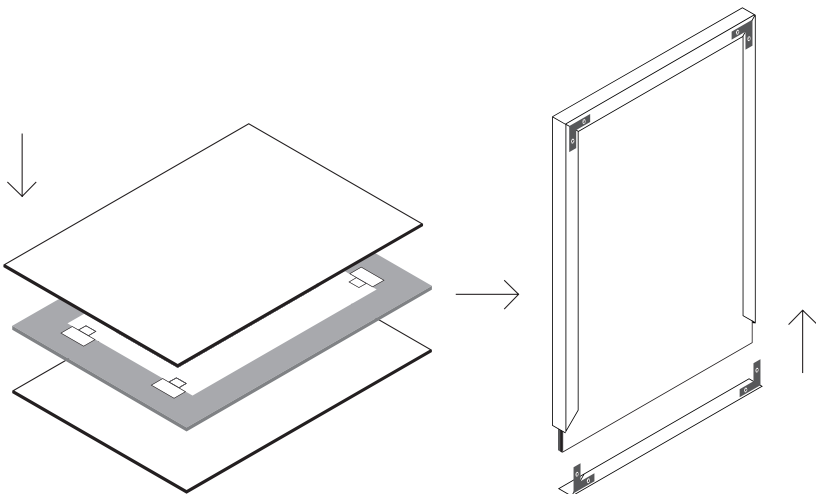

3 Re-insert spring clips

Secure the contents of the frame by re-inserting the spring clips between the frame edge and the backing board on the back side of the frame.

Place spring clips one at a time. Using your finger, push down on the top of the spring clip and gently slide the clip under the frame one edge at a time. Repeat until all clips are secure. The clips should be evenly distributed around the edge of the frame.

